



TEMO 600 TILLERHEAD

The TEMO 600 features a modular design and can thus be used in a wide range of electric-vehicle applications, for example in pedestrian industrial truck, transport trolleys, cleaning machinery, special applications, etc. Up to six control elements can be built into the upper housing of the TEMO 600: Pushbuttons and switches from the T switch range, the POLLANA thumbwheel or an INDICATO battery-status display. Combined with a UNIVERSAL or UNIVERSAL PRO traction switch with integrated body protection switch function compatible with the traction controller, the TEMO 600 can be optimally adapted to suit the customer's application. Various covers are available for the underside of the tiller head: For example with an integrated key switch.

- The modular design allows for a wide range of possible applications
- The number of buttons/switches and their functions are freely configurable
- Strong tubular handles
- Ergonomic control
- Optional multifunction cover
- Awarded with the following prizes: IF Design Award, Reddot Design Award and Materialica Design Award

Tiller heads



www.frei.de

Installation/removal

The upper part can be lifted off the lower part by unscrewing four socket screws (4 mm) on the underside of the tiller head.

The tiller head is screwed to a connection plate with three x M8 screws.

Tiller tube connection

The tube and the connection plate are not included in the delivery.



Technical data	
Operation elements	
Button/rocker switch/switch	See T switches datasheet
POLLANA thumbwheel	See traction switch datasheet
Horn	Microswitch NO Connector 2-pin
Optimum range of application	10 mA/5 V – 1.5 A/24 V
Creep speed (option)	Microswitch NO Connector 2-pin
Optimum range of application	5 mA/3 V – 50 mA/24 V
Traction switch	See traction switch datasheet
Tiller tube	Max. 40 x 70 mm
Standard colours	
Operation elements (button)	RAL 2011 deep orange
Lower part with handle	RAL 9005 jet black
Top and bottom cover	RAL 7015 slate grey
Personal protection switch	RAL 3000 flame red
Connector system	Molex Mini-Fit, Jr.™
Operating conditions	
Operating temperature range	-40°C to +85°C
Vibration test:	Based on IEC 68-2-6
Degree of protection according to DIN 40050	Tiller head IP 40 Operation elements and traction switch at least IP 54

Dimensions [mm]

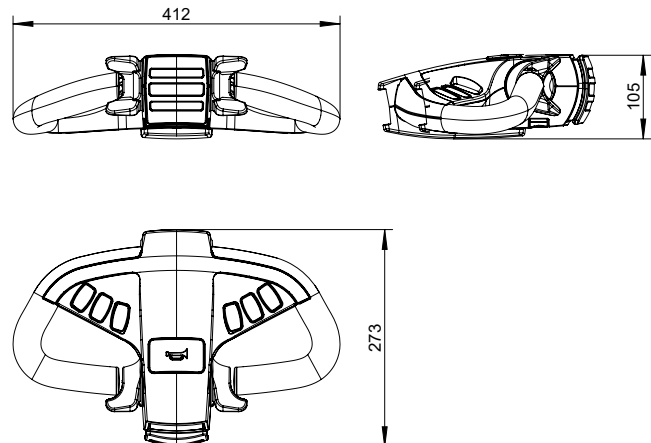

Information required for enquiries

- Number of buttons/rocker switches/switches/thumbwheels
- Controller designation for selecting the right accelerator pedal
- With or without multifunctional cover
- With or without mounting plate
- With or without creep speed
- With or without key-operated switch
- With or without special colours

Special versions

- The operation elements and traction switch lever can also be sprayed in different colours with an appropriate purchase
- Laser marking of the operation elements
- Multifunctional cover on the underside is suitable for integration of key-operated switches, buttons, switches, display, keypads, display elements
- Protective shield for round tiller tubes

Order data

Part No.	Designation
3101-00060-XXX	TEMO 600 tiller head is configured in a
3101-00061-XXX	customer-specific manner