



TEMO 200 TILLERHEAD

The TEMO 200 combines ergonomics and robustness. The modular design allows it to be used in many electric-vehicle applications. Features such as the traction switch, the body protection switch and the horn as well as an optional crawl speed switch on the underside are integrated in the housing. The upper housing cover can be fitted with up to two control elements from the T switch range, the POLLANA thumbwheel or the INDICATO battery-status display.

- Exceedingly robust plastic housing
- Ergonomically shaped handles
- Fatigue-free operation, as the controls are easy to reach and can be operated with a minimum of force
- Modular design allows flexible configuration
- Awarded with the Baden-Württemberg International Design Award, Focus Safety

Tiller heads



www.frei.de

Installation/removal

The upper part can be lifted off the lower part by unscrewing four socket screws (4 mm) on the underside of the tiller head. The tiller head can be screwed to a connection plate with three x M8 screws.

Tiller tube connection

The tube and the connection plate are not included in the delivery.



Technical data	
Operation elements	
Button/rocker switch/switches	Max. switching power 48 VDC / 1 A Min. switching power 24 VDC / 10 mA
POLLANA thumbwheel	Max. switching power 48 VDC / 4 mA transverse current
Horn	Wiper current < 0.1 mA Micro switch NO Connector 2-pin
Optimum range of application	10 mA / 5 V – 1.5 A / 24 V
Creep speed (option)	Micro switch NO Connector 2-pin
Optimum range of application	5 mA / 3 V – 50 mA / 24 V
Traction switch	Various traction switches available (for different con- troller manufacturers)
Tiller tube	Max. 40 x 70 mm
Standard colours	
Operation elements (button)	RAL 2011 deep orange
Lower part with handle	RAL 9005 jet black
Top cover	RAL 7015 slate grey
Personal protection switch	RAL 3000 flame red
Connector system	Molex Mini-Fit, Jr.™
Operating conditions	
Operating temperature range	-40°C to +85°C
Degree of protection according to DIN 40050	Tiller head IP 40 Operation elements and traction switch at least IP 578

Special versions

- The operation elements and traction switch lever can also be sprayed in different colours with an appropriate purchase
- Laser marking of the operation elements
- Protective shield for round tiller tubes

Dimensions [mm]

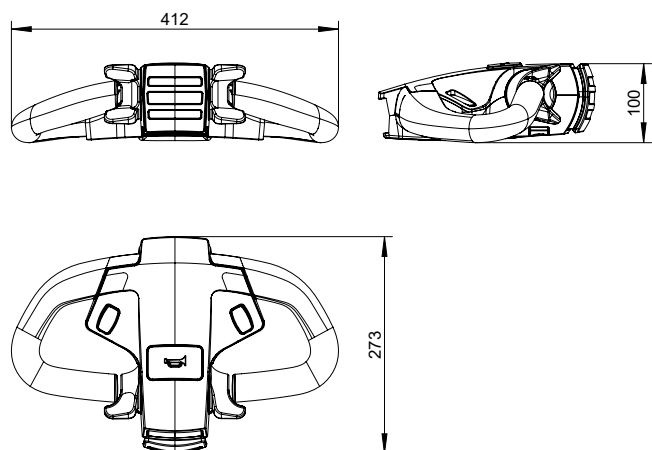

Information required for enquiries

- Number of buttons/rocker switches/switches/ analogue switches
- Controller designation for selecting the right accelerator pedal
- Creep speed function desired/blocked
- Colour selection

Order data

Part No.	Designation
3101-00020-XXX	TEMO 200 tiller head is configured in a
3101-00021-XXX	customer-specific manner